

Total energy supply for remote Human Habitations

(Or “Nuclear North of 60”)



Image courtesy of www.porkcoffee.com

Prepared by: Jay Harris
Port Elgin, Ontario, Canada
Band member of Cowesses First Nation

Jay.k.harris@gmail.com

‘Canned’ Version - Intended for viewing without a presenter

Foreword:

We have arrived at a crossroads in history. We are still beholden to fossil fuels, however we recognize that we cannot continue their use in such a profligate manner as in the past.

Energy policy has now become a prevalent concern among most nations on the planet. Environmental policy is shortly behind energy on the agenda of most. Following that, Human Security has arguably found it's place on the list following the first two. This is probably the first time in history that the priorities of any nation have been arranged in this manner. This is solely due to reliance of our modern world on energy.

We cannot be free from hunger without energy. We cannot shelter our families without energy. We cannot care for our sick, evacuate the ill, or even provide diagnoses of disease without energy. We can't see in the dark, cook our food, or manufacture the wealth that even poorest person enjoys today without energy in some form.

Energy has become our Human security.

Foreword: (Continued)

Since the dawn of time Humans have experimented with many types of energy. However we discovered one type of energy that came in many forms. It was relatively easy to collect, transport, and deploy. Fossil hydrocarbons have been used in Human civilization for millennia.

Coal was likely one of the first. Followed by surface tars, and other convenient petroleums.

What set this energy source apart from other sources like wood, is the tremendous amount of energy packed into a relative small mass. This mass to energy ratio, and relative ease of handling has kept fossil hydrocarbon the energy source of choice until very recently in history.

We have now in the last two hundred years combusted so many fossil hydrocarbons, that we have changed our environment.

It has recently become clear to most that these environmental changes threaten our Human Security.

Foreword: (Continued)

In terms of Human security we have reached a record level of population on the planet. We have now declared our favourite source of energy to be finite, and damaging to the habitat we live in.

In many (some would argue all) parts of the world we have now started fighting over the energy resources, in particular the fossil hydrocarbons. Possession and access to inexpensive, easy to handle energy has become a currency of sorts. In return, protection, policy enforcement, and wealth is offered.

This exchange has begun to shape our modern world.

No longer are we solely concerned with food, comfort, and shelter. We are now concerned with energy. In our modern world the first three are no longer possible without the fourth.

With the inclusion of energy as a basic tenet of survival, we must now also include physical security.

Foreward: (Continued)

We have all recognized the Fossil Hydrocarbons are finite. There are more than 6 Billion people alive today. This is due of course to the intervention that cheap plentiful energy has had on our planet.

It is estimated that by 2040 world population will reach 9 Billion.

In 2007 the State of California (37 Million) used more Gasoline and Diesel than China (1.3 Billion). *(source: Wired Magazine; 2008)*

What happens when everyone in the developing world demands a car?

What happens to the air? What happens to the environment? Where is the gas going to come from? How will the weather be in this future?

Will your children have to go to war to keep their civilization running at the expense of another?

Are all of these convenient Hydrocarbons really finite?

Hold on to this thought...We will come back to it.

A short history on Small Nuclear Reactors

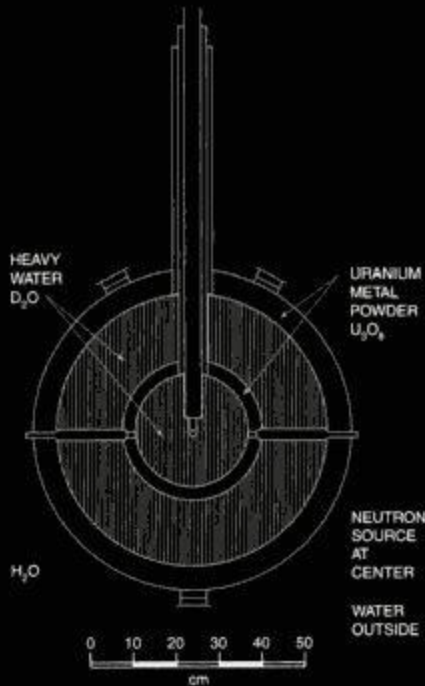

Heisenberg's
Leipzig L-IV; 1942

(Sub-critical pile; also the
world's first reactor
accident)



USS Nautilus; 1955

(World's first nuclear submarine)

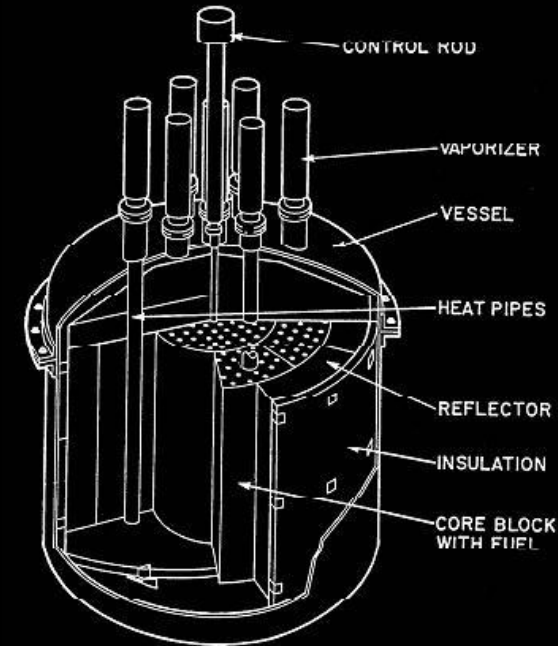

AECL Nuclear Battery
proposal; 1988

(600 KWe AECL proposal)

or; **“Planes, Trains, Automobiles...and lots of Boats”**

2 Billion years ago; Oklo, Gabon

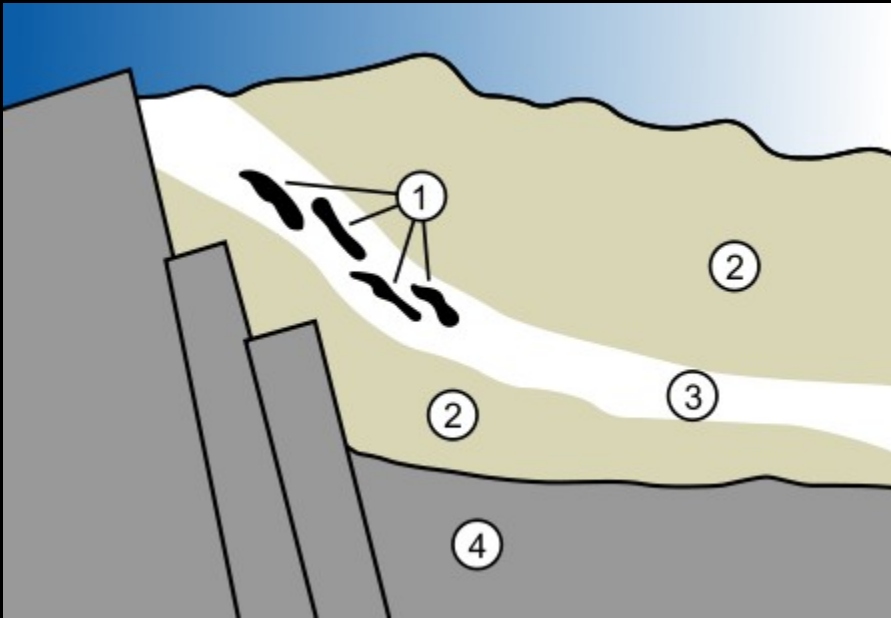

Geological situation in Gabon leading to natural nuclear fission reactors

1. High Uranium concentrations
2. Porous Sandstone
3. Uranium ore layer
4. Granite

2 Billion years ago natural uranium contained ~3% U-235 by isotopic content. The naturally occurring content of U235 was even greater at the creation of the universe, and is slowly decaying. At the present time it exists at 0.7% in Natural Uranium.

In the Oklo natural reactors water percolated through the bedrock, and collected in the Uranium deposits. The light (Natural) water provided a moderating effect, and the portions of the ore deposit with high concentrations of uranium became critical. The ore deposits effectively became naturally occurring, light water reactors.

Early research into Nuclear Fission

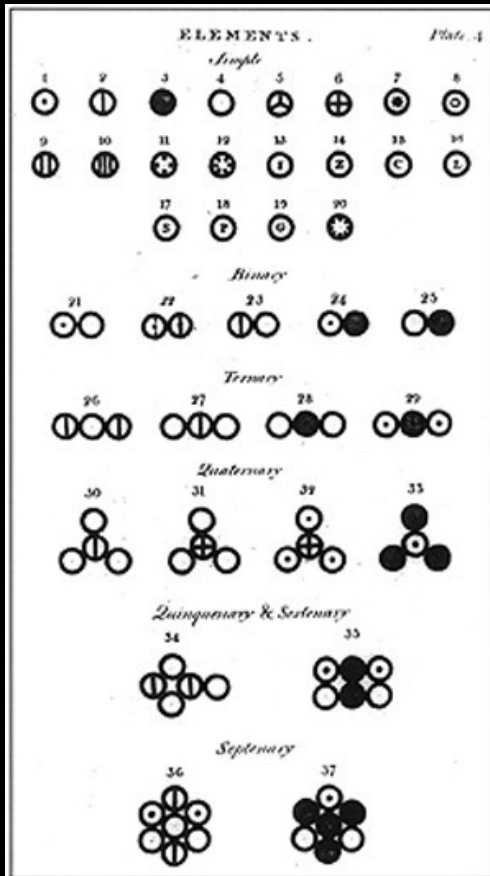

Various atoms and molecules as depicted in John Dalton's *A New System of Chemical Philosophy* (1808).

- 1805 John Dalton proposes the theory of the atom, and publishes his list of atomic weights.
- 1898 Pierre and Marie Curie discover Radium
- 1899 Ernest Rutherford classifies Alpha, and Beta radiation.
- 1900 Gamma rays discovered by Paul Villard.
- 1902 Gilbert Lewis proposes 'cubic model' of the atom.
- 1904 Hantaro Nagaoka proposes 'Saturnian Model' of the atom.
- 1904 J.J. Thompson proposes plum pudding model of the atom.
- 1911 Ernest Rutherford develops, 'Planetary atomic model'
- 1913 Neils Bohr develops the modern quantum atomic model
- 1914 Ernest Rutherford discovers Protons
- 1920 Rutherford 'predicts' existence of the Neutron
- 1929 Ernest Lawrence invents the Cyclotron
- 1932 James Chadwick discovers the Neutron
- **1934 Leo Szilard files a patent for an 'Atomic Explosive'**
- **1938 Lise Meitner, and Otto Hahn discover Nuclear Fission** in Nazi Germany. Meitner, in exile confirms Hahn's results.

1939 A busy Year



Hahn



Meitner



Strassman

January 1939: Hahn and Strassman publish their findings on fission. Meitner is not mentioned, however is considered by many to be the 'Mother of Fission' having interpreted the results of the experiment.



Straus

January 1939: Leo Szilard writes to Lewis Strauss, informing of the development of fission. Including it's applications both as an energy source, and as an explosive device.



Szilard

By the 26th of January 1939: Frisch in Copenhagen; Joliot in France; Dunning, Slack, and Booth at Columbia University all experimentally confirm the Hahn, Meitner, Strassman findings.

8th of March, 1939: Halban, Joliot, and Kawarski discover further neutrons are emitted in fission.

15th of March, 1939: At Columbia, Fermi, Anderson and Hanstein, and Szilard and Zinn, complete experiments which parallel the French work. Also on this date German troops seize the free remnant of Czechoslovakia.

April, 1939: The Paris team, and the Columbia group independently find that 2 or 3 Neutrons are emitted during fission. Enough to make a chain reaction possible.

1939 Gets busier still...

Albert Einstein
Old Grove Rd.
Nassau Point
Peconic, Long Island

August 2nd, 1939

F.D. Roosevelt,
President of the United States,
White House
Washington, D.C.

Sir:

Some recent work by E.Fermi and L. Szilard, which has been communicated to me in manuscript, leads me to expect that the element uranium may be turned into a new and important source of energy in the immediate future. Certain aspects of the situation which has arisen seem to call for watchfulness and, if necessary, quick action on the part of the Administration. I believe therefore that it is my duty to bring to your attention the following facts and recommendations:

In the course of the last four months it has been made probable - through the work of Joliot in France as well as Fermi and Szilard in America - that it may become possible to set up a nuclear chain reaction in a large mass of uranium, by which vast amounts of power and large quantities of new radium-like elements would be generated. Now it appears almost certain that this could be achieved in the immediate future.

This new phenomenon would also lead to the construction of bombs, and it is conceivable - though much less certain - that extremely powerful bombs of a new type may thus be constructed. A single bomb of this type, carried by boat and exploded in a port, might very well destroy the whole port together with some of the surrounding territory. However, such bombs might very well prove to be too heavy for transportation by air.

April 1939: American, British, French, German, and Russian scientists all approach their respective governments to seek support for fission research and a watch on uranium supplies.

September 1st, 1939: Germany invades Poland, World War II begins in Europe.

Bohr and Wheeler publish theory of fission; they show that only the isotope U-235 will fission more easily than U-238, and is more likely to occur with slow neutrons building on the research of Fermi in the U.S. ***This is one of the last openly published papers on fission research.***

August 2nd, 1939: Szilard drafts, then Einstein signs and delivers a letter to President Roosevelt. In it he indicates the military implications of fission, and uranium. Roosevelt sets up an advisory committee on Uranium.

From 1939 to 1945; a great deal happened. Including the Manhattan Project, and the bombings of Nagasaki, and Hiroshima. We will only deal with issues relating to small, modular, and deployable reactor technology. Some mention of other milestones will be included for reference.

April 1942; (Germany) Werner Heisenberg achieves 13% neutron multiplication in the Leipzig L-IV pile (reactor). The L-IV is driven by a neutron source, and is not a self sustaining fission reaction. As such it is not considered to be the first “Critical” reactor.

June 23rd, 1942; The Leipzig L-IV is destroyed in a fire. The powdered Uranium fuel of the L-IV is contaminated by water leaking into the fuel jacket. A pyrophoric reaction occurs, and Heisenberg’s Leipzig lab is destroyed in a fire. The Leipzig experiments are abandoned in favor of other reactor designs.

December 2nd, 1942; Enrico Fermi achieves criticality in the Chicago Pile, as part of the Manhattan Project.

The Chicago Pile CP-1

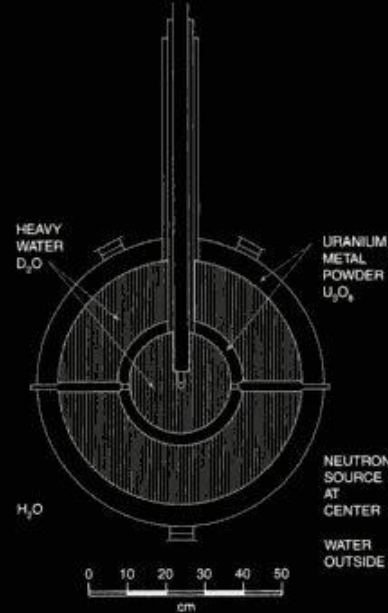

The Leipzig L-IV

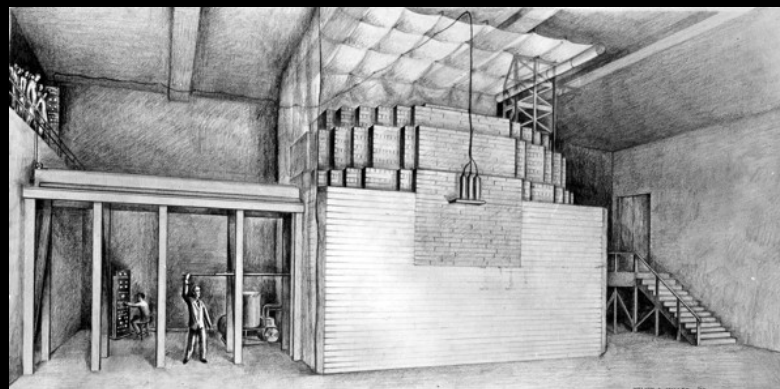

Also in 1942; Paul Harteck (Germany) perfects the gaseous centrifuge for Uranium enrichment, building on the earlier work of Eric Bagge (Germany). This remains the most prevalent method of Uranium enrichment today.

July 1943; The Kriegsmarine (German Navy) moves the U-boat nuclear propulsion project from Hamburg following American aerial bombardment. Admirals Otto Rhein, and Karl Witzell oversee the project. Physicist Dr. Otto Haxel takes over scientific leadership of the “Oberkommando der Marine” (OKM) nuclear project.



Type XXI Uboat, proposed platform for Kriegsmarine Nuclear Propulsion Program

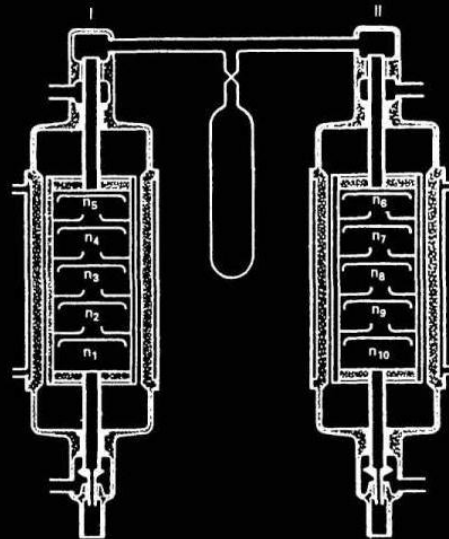

Harteck's double rocking gas centrifuges



Dr. Paul Harteck

In April 1944 Paul Harteck (Germany) gains funding for industrial scale enrichment of uranium. Orders were placed with BMAG Meguin for production of gaseous uranium centrifuges.

May 7th, 1945 Germany Surrenders.

August 15th, 1945 Japan Surrenders. World War II is officially over.

May 28th, 1946; US Army Airforce undertakes the “Nuclear Energy for the Propulsion of Aircraft” Project.

1953; Under the leadership of Admiral Rickover the first U.S. naval reactor achieves criticality.

1954; The US ARMY Nuclear Power Program (ANPP) begins.

June 27th, 1954; (Soviet Union) The AM-1 the world’s first Civil Nuclear Power Plant is commissioned at Obninsk, Russia (6 MWe). After 48 years of accident-free operation the plant was shut down on the 29th, of April, 2002.



Undated photos of the Obninsk Power plant. Located 102 km's southwest of Moscow.



June, 1954; Dr. Lyle B. Borst proposes an atomic locomotive. The X-12.

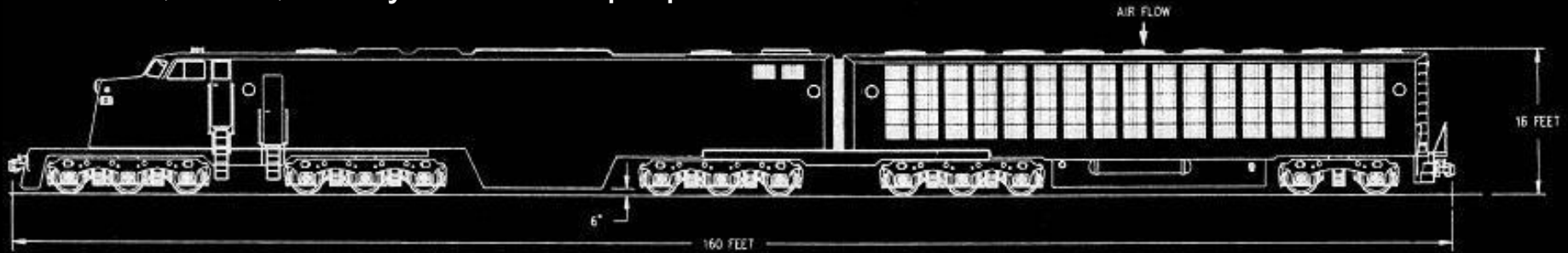

The X-12 was to feature a Uranyl Sulfate liquid fuel reactor. The locomotive was to include 'on power', and 'on board' **reprocessing** equipment. Refuelling intervals were projected to be as long as 10 years.

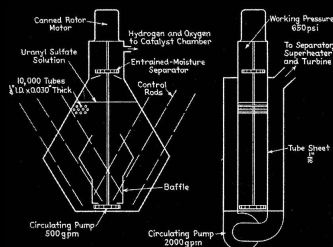
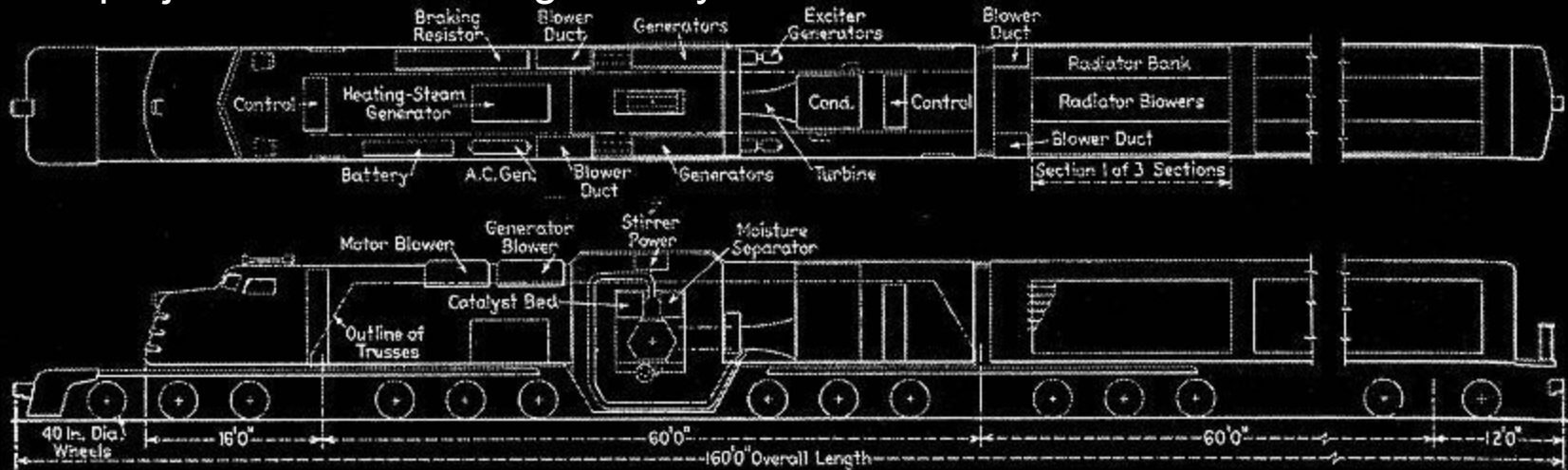

The X-12 was to compete economically with diesel locomotives of the day when amortization of the long fuel cycle was considered. It was never constructed.

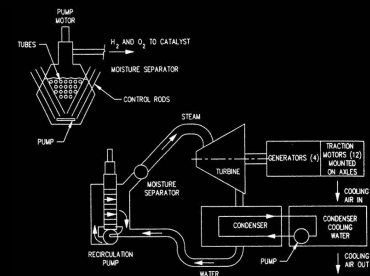

Circa 1950's another Atomic locomotive proposal from West Germany.

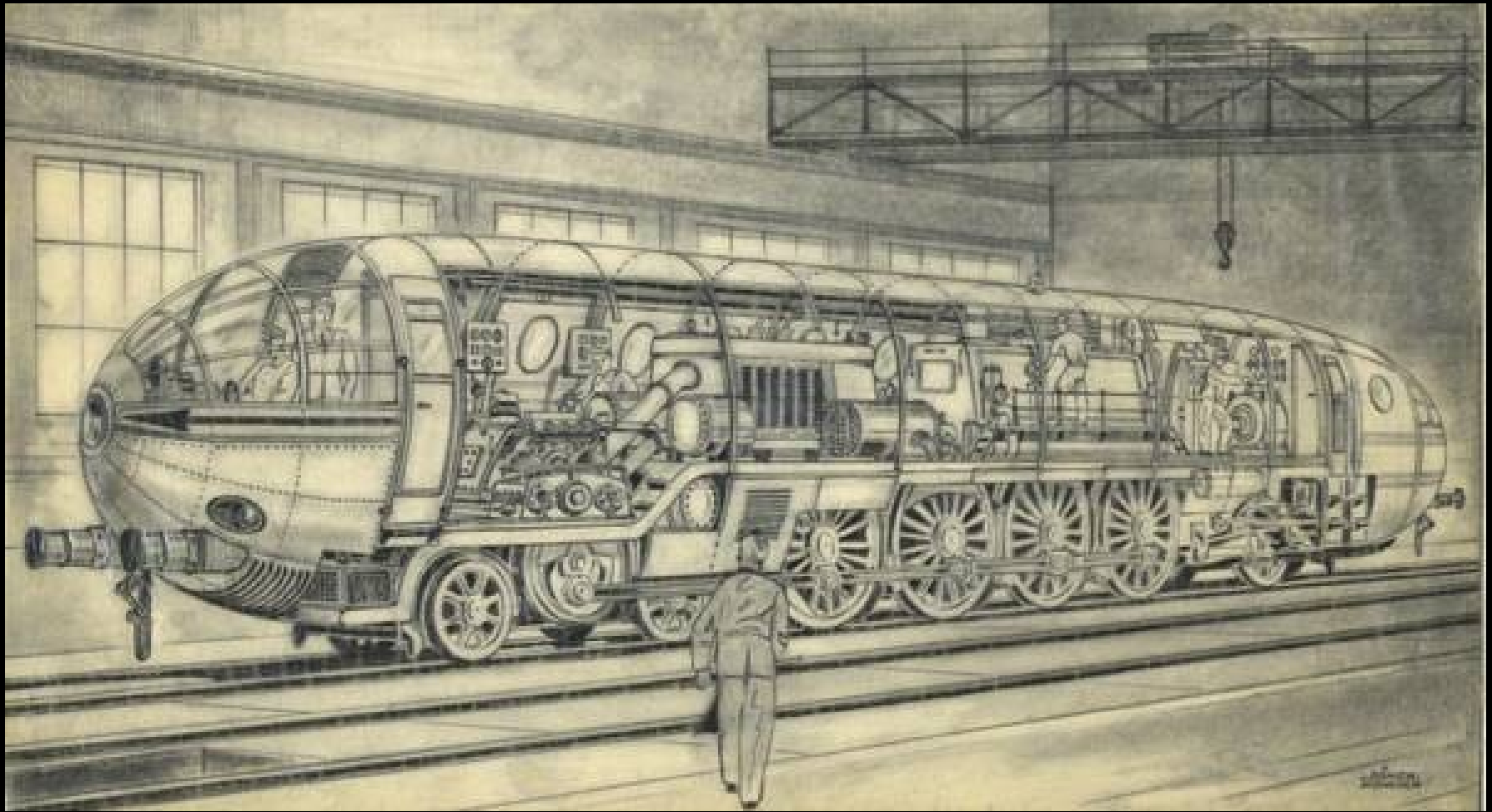
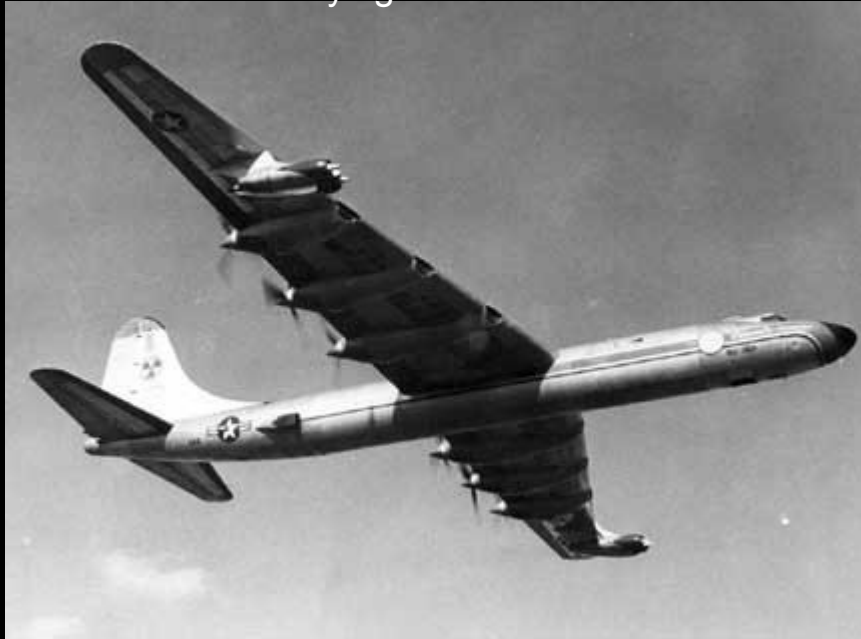

Image courtesy of the "Deutsches Museum" www.deutschesmuseum.de

July 1955; First flight of the Convair X-6 with a 3 MW thermal air cooled reactor. The reactor is not propulsive, but only for airborne shielding tests.

Convair X-6 Flying reactor test bed



WS-125 Nuclear Powered bomber concept

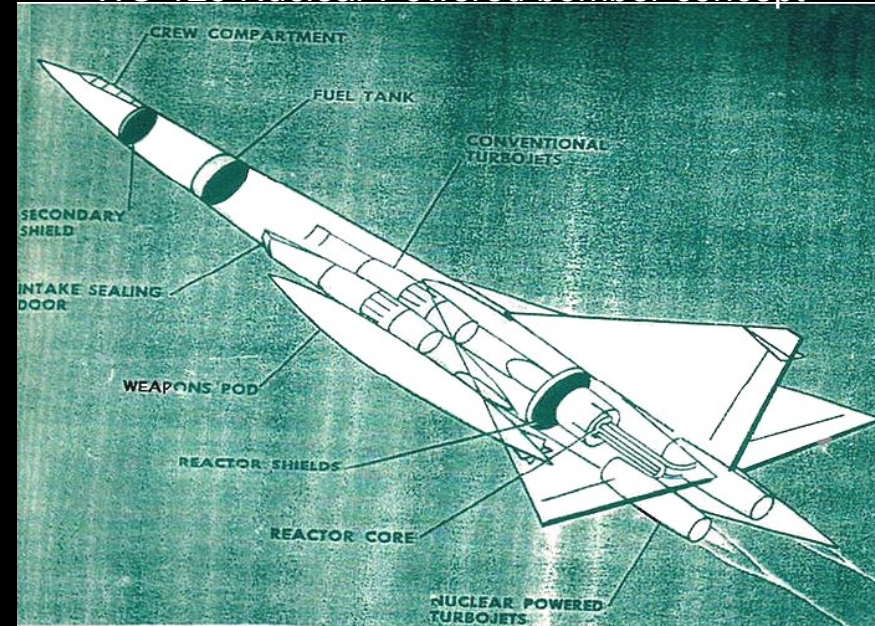

The HTRE-3 without supporting structure.

Left: The HTRE-3 reactor showing the relation of the turbines to the reactor.

Right: The HTRE-3 reactor – turbine test stand. *(Yes it worked!)*

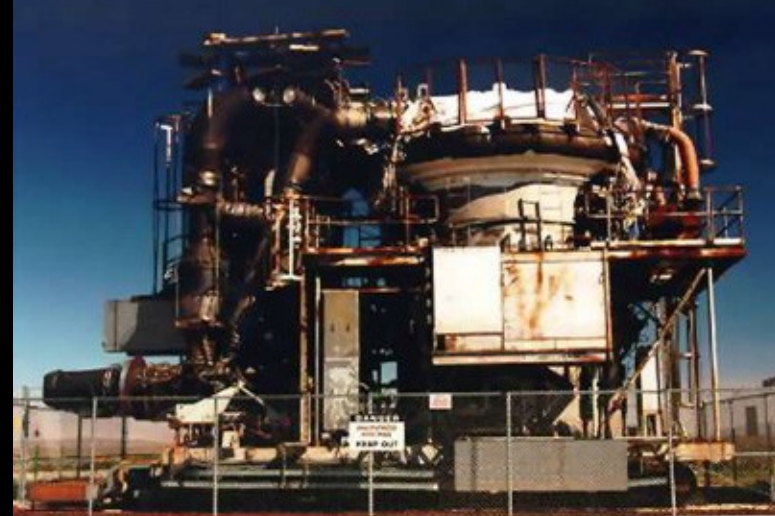

HTRE-3

August 12th, 1955; The Council of Ministers (Soviet) issues a mandate for the development of a Nuclear Powered Bomber.



Tupolev TU-95 LaL Flying reactor test bed



An early impression of the Myasichev M-60 Nuclear powered bomber.

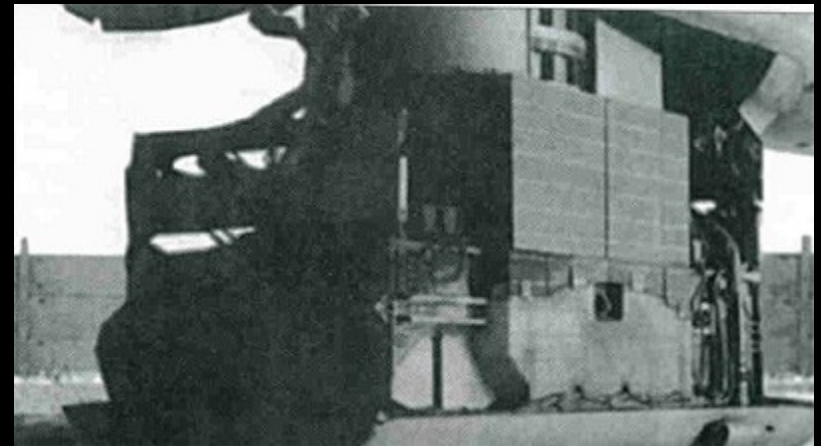

Bomb bay mounted flight test reactor TU-95

Early 1961; Soviet Leadership calls for the cancellation of all Nuclear Aircraft Propulsion projects.

1955; The USS Nautilus, becomes the world's first nuclear powered submarine.



The USS Nautilus; circa 1964

April, 1957; The SM1, a 2MWe reactor achieves criticality under the ANPP.

July, 1958; The Soviet Union puts it's first nuclear submarine into service. The K3 'Leninsky Komosoll', the first November class remained in service until 1988.

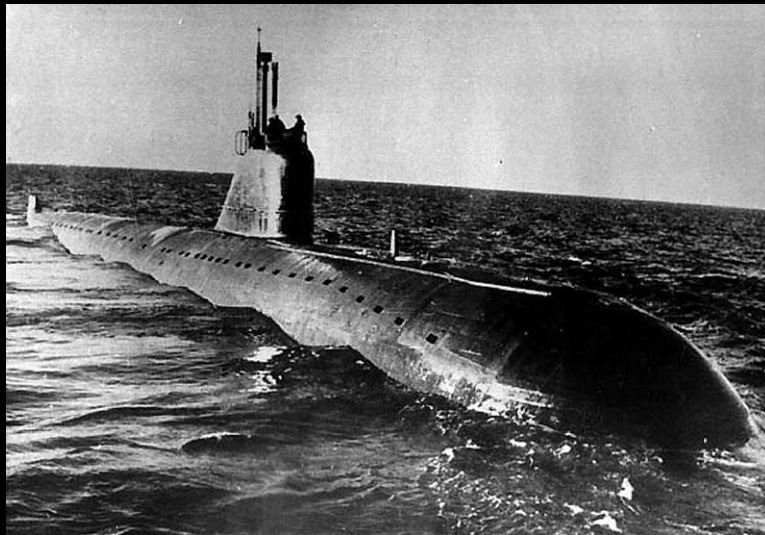

Left: A 'November' on patrol. (Undated photo)

Right: K-159 (November class) tied up in 1989. In 2003 with 800 kg's of spent fuel still on board it sank while being towed for decommissioning. Nine Russian Sailors died in the accident. The wreck, and the spent fuel have still not been recovered. (as of 2008-09-01)



Photo provided courtesy of the Bellona Foundation
<http://www.bellona.no/>

1959; (Soviet Union) The NS Lenin a Nuclear Powered Icebreaker enters service as the world's first Nuclear Icebreaker, and the first Nuclear Civilian vessel.



A postcard, and postage stamp featuring the NS Lenin. The Stamp is dated 1978.

October 1960; The PM2A, 2 MWe, (plus district heating) Achieves criticality, at Camp Century, Greenland. The first "portable" nuclear power reactor. Brought to Greenland in parts, assembled, operated, disassembled, and shipped back.



Far Left: The PM2A core. Remaining photos are images of the 'under the ice' nature of Camp Century.

Camp century was constructed 'under the ice', and existed in a tunnel, and covered trench architecture. The PM2A contaminated waste water was not recovered and remains in the Greenland icecap today.

January 3rd, 1961; ANPP reactor, SL-1 is destroyed in a suspected suicide by an operator. This reactor was intended for use at Distant Early Warning (DEW) line radar stations in Canada. Due to the incident, and Canadian sensibilities this reactor was never deployed.



SL-1 Reactor Building prior to January 3, 1961. U.S. National Reactor Testing Station near Idaho Falls, Idaho, United States.

August 13th, 1961; Construction of the Berlin Wall begins.

1961; The U.S. Airforce Aircraft Nuclear Propulsion project is cancelled. The project ran in one form or other from 1946 to 1961, and cost \$7billion USD

1962; The NS Savannah (United States) enters service. The second civilian nuclear vessel, but the first civil nuclear cargo vessel.



The NS Savannah

Sometime in 1961; The TES-3 concept is commissioned at Obninsk, Russia.

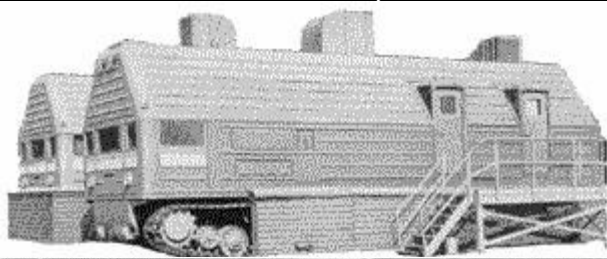

Left: TES-3 Mobile Reactor mounted on four crawler transporters.

Below: TES-3 In deployed, and mobile mode.

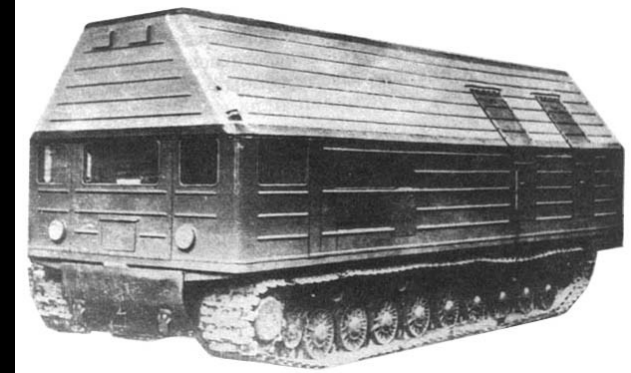
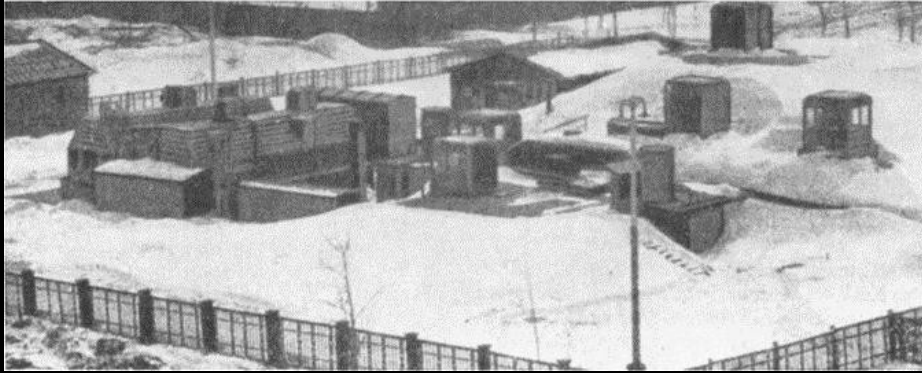

The TES-3 was a 2 MWe, and 8.8 MWt reactor. The unit was intended for remote air defence bases. This reactor was light water cooled, and used Highly Enriched Uranium fuel. The unit was intended to be shielded with earthworks at the establishing site. There is no indication this design went into production, or deployment beyond prototype testing.

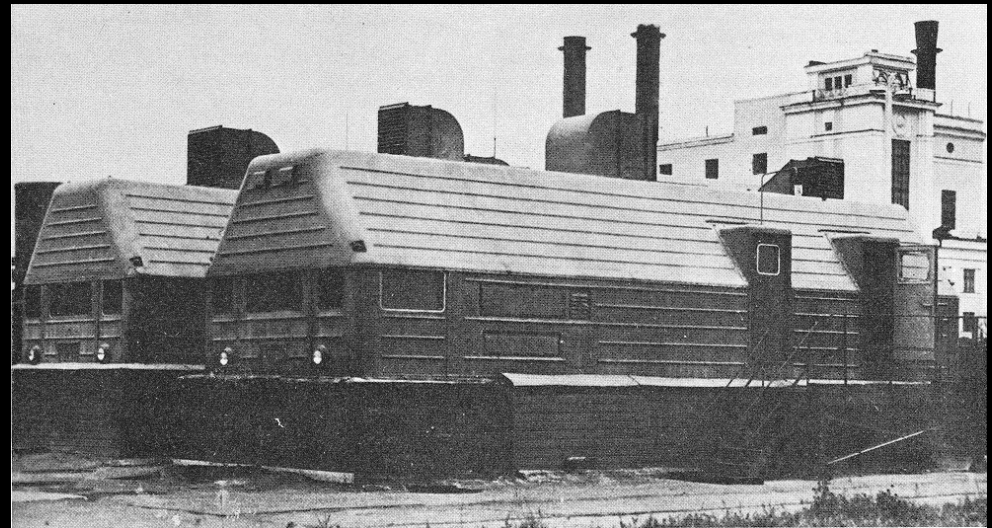

1962; ANPP reactor PM1 is commissioned at Sundance, Wyoming, and operated by the U.S. Airforce. The Unit powers a radar station providing 1.25 MWe, plus district heating until decommissioning in 1969.

March 1962; The PM3A ANPP (Navy operated) reactor is deployed to McMurdo Station, Antarctica. This reactor continues to operate until 1972 when it is taken out of service due to a leak. The reactor provided 1.75 MW of Electricity, seawater desalination, and district heating. The reactor, facilities, and 7700 cubic meters of contaminated dirt were removed to California on decommissioning in 1972



McMurdo Station, Antarctica

March 1962; The SM1A ANPP is deployed to Fort Greely, Alaska. Providing 2 MW Electrical plus district heating. This reactor was decommissioned in 1969. The site suffered several mechanical incidents, including a frozen cooling pipe resulting in large environment discharge of activated water to the environment. The reactor has since been disassembled, and removed from the site.

Fort Greely Reactor building

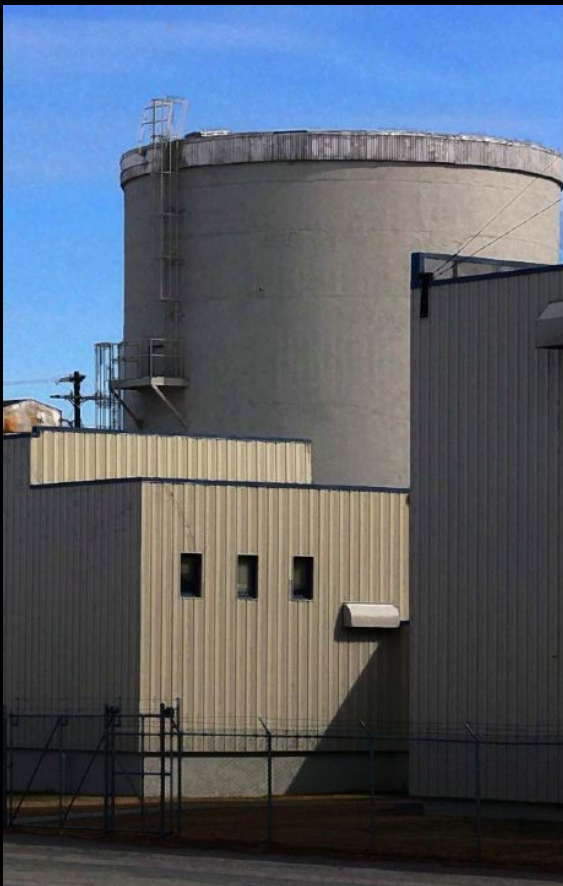

Fort Greely, Alaska



Image courtesy of Mark Farmer

1967; The MH-1A (ANPP) goes critical. As a 'barge' mounted reactor, it was positioned in Panama in 1968, providing 10 MW of electricity, and desalination to the adjacent base. The unit was removed in 1976 with cessation of U.S. zone ownership. This unit was built on the hull of a 'Liberty ship' (SS Charles H Cugle), and became the first floating nuclear power plant, renamed "The Sturgis".



The MH-1A installed in "The Sturgis"



Containment vessel of the MH-1A reactor

March 28th, 1979; The generating Station at Three Mile Island suffers a partial core meltdown. There is a release of contaminated water from the plant due to operator error, and equipment malfunction, however the containment of the Reactor Vault remains intact.

1979 (approx.); The U.S. Army Nuclear Power Program (ANPP) ends.

1981 (Approx.); The Soviet Union begins work on the Pamir concept. This is a reactor plant built on two off road trucks originally designed to carry mobile ICBM's. The reactor was designed to produce 650KWe, and use no water. It was cooled with Dinitrogen Tetroxide. During the development 60 emergency shutdowns occurred, resulting in releases of N_2O_4 , and radioactive particles.



The Pamir Project was cancelled in 1986.

Early 1980's; The Royal Military College of Canada, works on a proposal to develop an Autonomous Marine Power Source (AMPS). This module was based on Slowpoke (unpressurized) reactor technology, driving an organic Rankine cycle (Freon turbine), to constantly recharge the submarine's batteries. This module was supplementary to the vessel, it was never meant to replace the diesels of the sub.

1984; **International Submarine Transportation Systems Ltd** is formed in Canada; a consortium of four companies. The French Institute for Exploration and Exploitation of the Seas (Ifremer) 25%, COMEX SA a French underwater salvage company 25%, International Submarine Engineering Ltd owning 45%, ECS Energy Conversion Systems Inc owning 5%. ISTS proceeds to jointly develop a civil submarine powered by the AMPS concept. This project is built on the hull of an existing submersible. The craft is named the "SAGA-N".

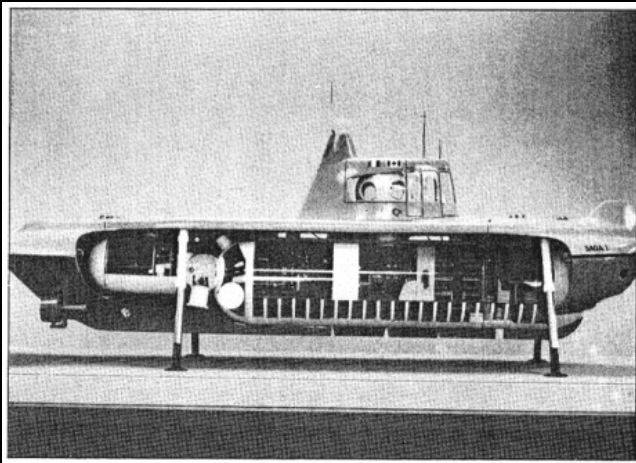

Images of the SAGA-N courtesy of the Canadian Nuclear Society.



In 1987; The project was cancelled due to a tax dispute over a research grant.

26th, of April 1986; The Chernobyl disaster occurs, near the Ukrainian town of Pripyat. During a test of emergency equipment the cooling pump's power supply is turned off, subsequently nearly all the control rods are removed from the reactor by an operator. The reactor power reaches 12,000%, a steam explosion occurs destroying the reactor vessel and most of the plant.

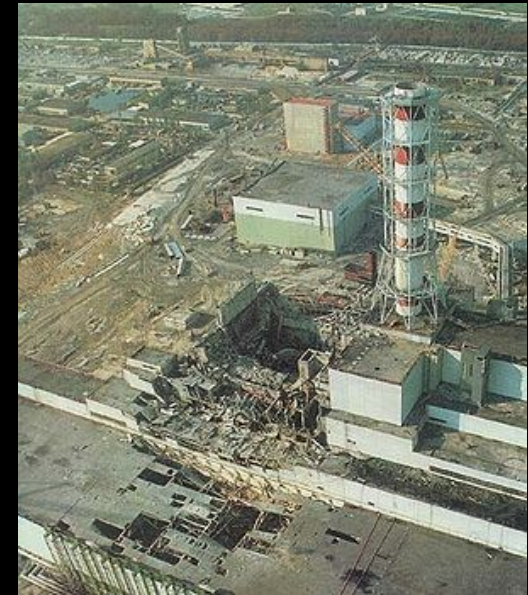

As was common with most Soviet era reactors the plant has no reactor containment. The fuel melts, and partially homogenises with the reactor's graphite moderator. The melted fuel/graphite mass melts through the remaining reactor vessel, and into the basement of the plant. The reactor building having no real containment is partially destroyed by the steam explosion, the ensuing fire then spews radioactive particles, and steam out of the building and into the environment. Radiation detectors throughout the northern hemisphere detect fallout from the reactor catastrophe.

1988; Atomic Energy Canada Limited proposes and partially develops the AECL Nuclear Battery.

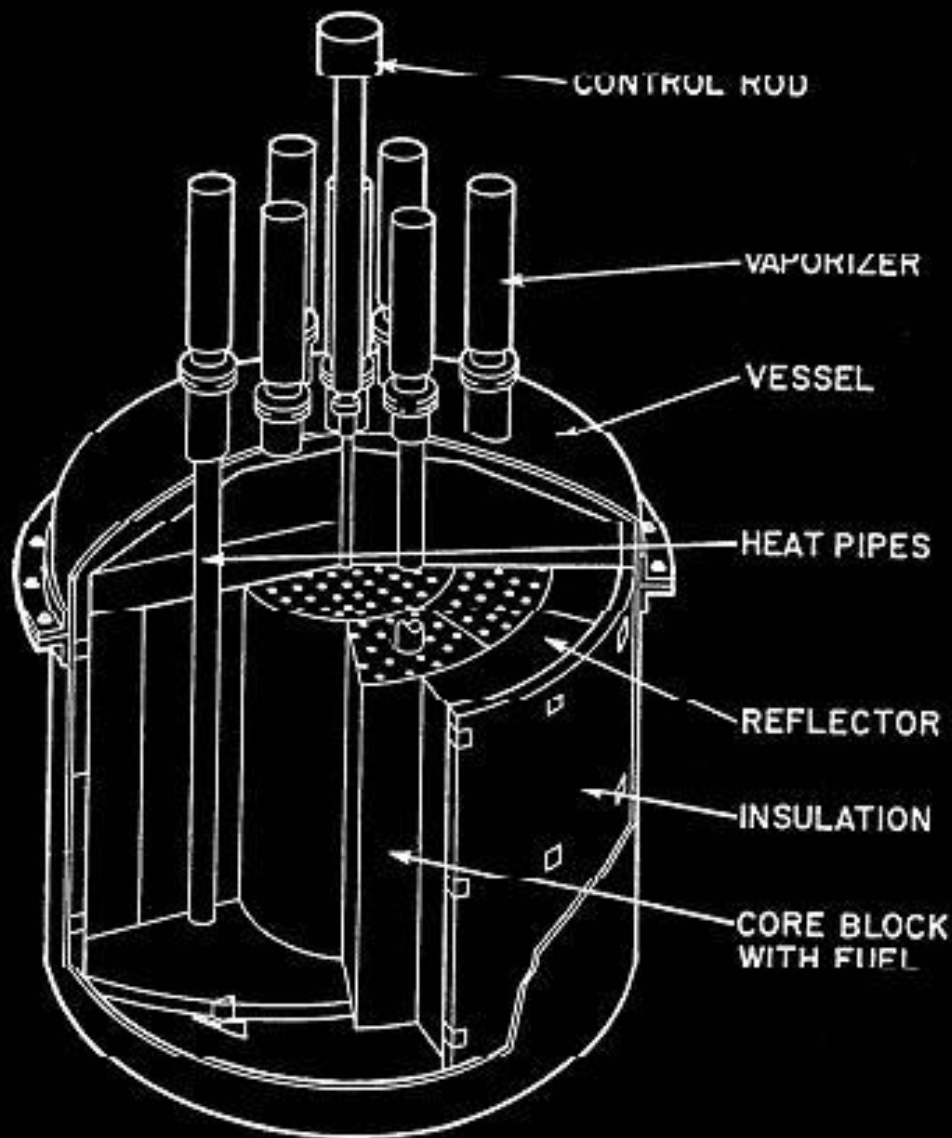

The AECL nuclear battery was to use low enriched uranium, and was graphite moderated. It was designed to be inherently safe (Hands off). It was passively cooled with heat pipes, and with its low power density would not have enough energy to raise the core temperature high enough to allow any damage to the core or fuel assemblies. Further enhancing safety the design featured 'doppler broadening' which reduces the likelihood of fission as the core temperature rises. Thus if the core temperature exceeded engineered limits, the rate of fission would slow and lower heat output of the reactor.

This reactor was expected to operate for 15 full power years as a sealed unit, producing 630 KW of electricity.

After the Accident at Chernobyl and the end of the Cold war, interest in small reactors outside of naval applications waned. With the exception of the Gulf War period, the price of fossil fuels did not economically favour the development of nuclear reactors. Further there was little interest in curbing Greenhouse gas emissions.

Some research did continue though, though mostly related to military applications.

In the mid 2000's the price oil rose above \$80US a barrel.

In 2005; Al Gore released his "An inconvenient truth" documentary.

In July of 2008; Oil peaked at \$147US a barrel.

At the present time there are a number of reactor developers that are, and have been working on small, modular, and deployable reactors. Some already exist like the Russian naval variant small reactors, while others remain in the proposal stage. A large number of small reactors have already been built, and tested as you have seen. Most are in varying states of development, and range from truly revolutionary to utterly conventional. As you have seen small reactors have already been used in isolated human settlements, and in remote Arctic conditions.

In 2007, the Territory of Nunavut spent \$237 Million (CAD) on fuel, and fuel subsidies. -

This was before the oil spike in July of 2008.

Why would anyone want a small reactor?

A more important question is really,

“What can you do with a small reactor?”

1. You can generate electricity, a lot of it. Also most of the new designs are very scalable, and aggressively load follow (*You can throttle them*). Additionally they don't need to be refuelled for 1 to 15 years depending on the model.
2. You can heat a community with one using only the 'waste heat'. This technology is already being used in Switzerland, and Germany. The recovery of the low grade heat gives the reactor a near 'neutral' thermal footprint for most of the year. This technology is called “Kaltefermewarmen”, or Cold district heating. There will be more heat than you can use. It is also simpler, and more reliable than other district heat systems.
3. You can use all this excess electricity, and heat to produce hydrogen. Heat greenhouses to produce more food locally without the shipping costs. Use greenhouses to produce Jatropha biodiesel for vehicles, and even jet aircraft.
4. You can make synthetic hydrocarbon petroleums, out of the air, and water. In the last twenty years, the United States has been working on technology which will produce synthetic gasoline, diesel, and jet fuel by capturing Carbon from the air, electrolysing Hydrogen from water, and chemically recombine the two in various chemical forms. These fuels would be essentially “Carbon neutral”, as they were made by harvesting carbon from the atmosphere.

Why would anyone want a small reactor?

A more important question is really, “**What can you do with a small reactor?**”

As we've already seen we can provide electricity, heat peoples homes and businesses. We can grow food in greenhouses with our large heat and electricity surplus. Further we can produce motive fuels for vehicles through Hydrogen, Biodiesel, and synthetic petroleum fuel processes.

Heating, lighting, food, and fuel for vehicles. None of which would rely on re-supply from the outside world. None of which would contribute to global warming.

Sounds good doesn't it? So what's the catch.

The Catch...es!

Reactors, District heating, Fuel plants, and even Greenhouses have high initial acquisition costs.

While most of these technologies have already been deployed, few of these have ever been deployed together. Also the fuel from atmosphere process has not been developed beyond bench testing of the concept.

Further this places the reliance of an entire community, on single centralized processes. Reliability, and redundancies need to be carefully worked out prior to deployment.

Further many of the target communities that would want these technologies, are extremely isolated. Some of these communities are a two hour flight in an airliner from Iqaluit. There are no roads, and for 10 months per year they are cut off from sea by impassable ice.

We will examine these needs further in the *“Duct tape doctrine”*.

The Catch...es! Part II !!!

The Regulator Strikes Back!!!

Presently nuclear power plants must have security capable of dealing with a credible armed threat to the plant. The actual standard is not public information, but it was increased in 2006 after the arrest of the “Toronto 17”. At present it is speculated that the standard requires an operator to have the ability to repel 20 armed, determined attackers. Having a security force of this size to protect a 10 Megawatt reactor is not economically feasible.

Further the technology selected must feature a great deal of inherent safety. No expense can be spared in terms of containment, system sequestration, process separation, or environmental integrity.

In the case of a serious event the residents have nowhere else to go.



The town of Resolute Bay from a hill overlooking the bay

Photo: G. Osinski, Canadian Space Agency

The Duct Tape Doctrine

Any system that doesn't meet the following criteria, is not deployable.

The requirement for nuclear grade materials, and engineering **must** terminate as close to the reactor as possible.

All processes must be repairable with common hand tools, or things that would commonly be found in a remote arctic community.

Spare parts must be small, simple, cheap, common, field modifiable, and easily stored in significant quantity with no 'shelf life'.

Each process should be physically separate, redundant, and be easily isolated with minimal disruption to any of the other processes.

Taming the Regulator.

(or “You can’t beat the house!”).

Security, Proliferation, Safety, Environment, and Emergency management



While there are a number of organizational models which would be suitable to small reactors in isolated communities. There is one which should not be expected as suitable under any of the above mentioned headings, to any of the listed parties.

Individual owner operators of single nuclear reactors. Whether by local governments, corporations, coop’s, etc.

Why not 'Owner Operators'?

- 1. How would you demonstrate to the regulator a plan for security?**
 - Two Mountie's and a snowmobile won't cut it.
- 2. How would you demonstrate your ability to handle a catastrophic emergency?**
 - In many isolated communities there is nowhere else to go. Period.
- 3. If you had an environmental event how would you handle it?**
 - Borrowing the airport's front end loader is not a 'capability'.
- 4. How would you convince a regulator that you are qualified to operate a nuclear reactor?**
 - Experience counts.
- 5. Who would be left holding the bag if an operator ceased to exist, went bankrupt, or just disappeared?**
 - The public purse? The Federal, Provincial, Territorial Government?

So who would be suitable?...

A Fleet operator with a centralized support site.

Preferably one that is already an existing Nuclear operator.

Basically any existing Nuclear Operator. There are four in Canada, and many more internationally that have been expressing interest in expanding beyond their own national borders.

Existing sites with existing operators offer the expertise to manage, operate, maintain, protect, and provide Emergency and Environmental support.

Further existing sites usually offer fuel handling facilities, training and education infrastructure, and large bodies of experience staff.

The addition of a remote fleet of small reactors, would require (In relative terms) a small increase in capacity, and capabilities to an existing centralized site.

What sort of new capabilities would an operator have to add to service this area?

Heavy Airlift, and Rapid Airlift



What if...?

Terrorists tried to steal nuclear materials from one of these sites? What if they got in and blocked the runway? How would your security response work?



All of the prospective vendors have developed 'hardened' access, and designed their reactors to make it difficult to remove materials at the site. In some cases the reactors are actually buried great distances underground, and feature sealed vessels. This is without considering the deadly fields coming off of the materials themselves which would require special, and extensive handling facilities to remove from the site. It would also be important to remember that an initial response need only prevent these parties from leaving the site with the materials.

All of the sites would require monitoring in real time, security patrols, and inspections at regular intervals.

What if...?

There was an emergency?

In nearly every small reactor product, the core contains a relative low energy density. Further nearly all of the designs that could compete in this market feature inherent passive safety. In layman's terms this is known as 'hands off' safety.

This means that even if you did nothing during a unexpected event, no failure would occur. In some cases the products cannot be made to fail even under malicious attempts. A number of the new generation small reactors rely on something called Doppler Broadening to reduce their reactivity as the temperature goes up.

Chinergy, a developer of a pebble fuel reactor in China, recently removed all the control rods, and turned off all the cooling in one of their prototype reactors. They let it sit in this state for days. The temperature of the core never exceeded design limits.

-Source 'Wired Magazine'; "Let a thousand reactors bloom" September 2004.

Additionally new fuel technology (Triso for example), has raised the failure temperature of fuel assemblies to a very high temperature. These new encapsulated particle fuel designs do not permit anything to escape from the fuel, and are very resistant to extremely high temperatures.

What if...?

There was an emergency?.....But what if THERE WAS!!!!

Presently every year the inhabitants of many remote northern (Provincial) communities face the reality of forest fire. In many cases the inhabitants of some of these communities have to be evacuated. As in the past this has been undertaken by charter flights, RCMP aircraft, medivac flights, and even Canadian Forces Aircraft.

The total evacuation of northern isolated communities is not without precedent.

Additionally, it would not be expected that the community power plant would be located in the middle of town. The placement of the generator could be done at a reasonable, but accessible distance from the community. This would likely be the most reasonable deployment for any small nuclear generator for an isolated community. This would also be suitable for reasons of security, and environmental monitoring.

Given that the peak electrical demand of the capital of Nunavut is less than 10 megawatts electrical, a Hyperion power Module (27MWe) would be far more than enough. In terms of scale, an HPM can fit in a rail car. The scale of any 'supposed' emergency has to be realized against the size of any technology selected.

Emergency and Security Preparedness

The final word...

A fleet operator will have to provide security, and emergency response to support a given fleet of small reactors. Environmental monitoring, and emergent response would also be required.

This could only be accomplished over the great distances, and in these isolated locations with centrally coordinated air mobility, and remote monitoring.

Pre-deployment kits, for security, environmental, and emergency situations would need to be assembled, and inventoried for immediate deployment by aircraft. The pre-deployment kits would be similar in nature to the Canadian Forces Major Air Disaster Kit. The 'Majaid' kit is stored in air deployable containers, and can be air dropped. It contains a nearly complete field hospital, in addition to other materiel useful during a major air disaster.

This permits extremely large, and forceful responses in a wide geographical area, even if suitable airports were not accessible, or serviceable.



A Hercules aircraft drops the major air disaster (MAJAID) kit at the simulated crash site near Comox during Artic SAREX 07.

Total Energy Cycle...

What does it mean? How do we do it?

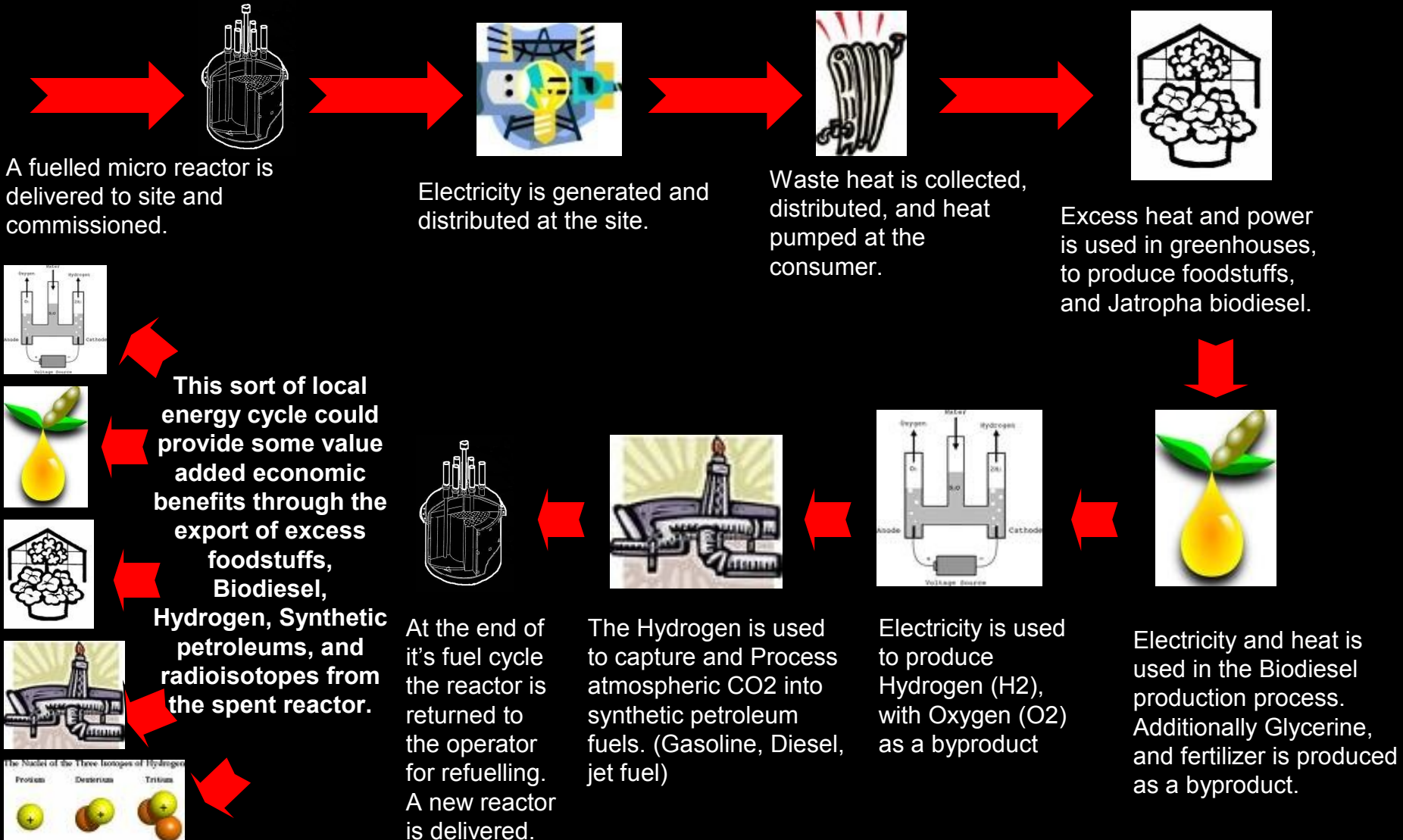

Total Energy Cycle...

What does it mean? How do we do it?

Electrical Production and distribution

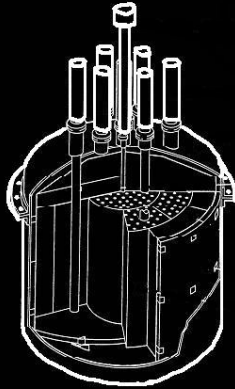

=



Carried out in the conventional manner (Mostly).

(We will not examine it here)

Total Energy Cycle...

What does it mean? How do we do it?

“KalteFermewarmen” or Cold District Heating



The heated coolant is heat pumped at the customer.

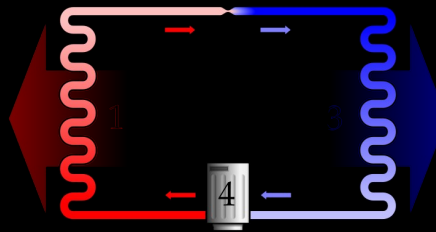

Core cooling, Condenser cooling, all sub 100c waste heat.

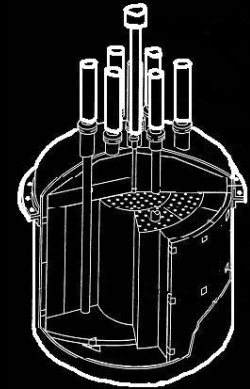

Beznau NPP Switzerland

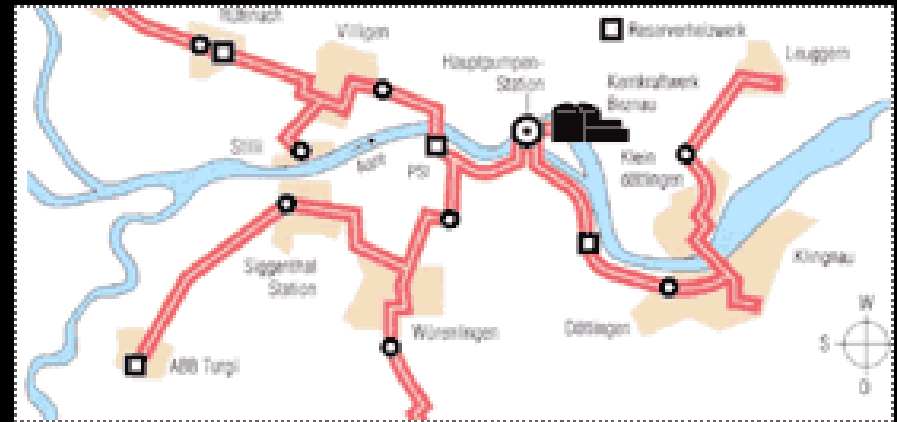

Refuna District heat network

Total Energy Cycle...

What does it mean? How do we do it?

Greenhouse Production

Foodstuffs, and Biodiesel

ᑎᓄᓐᓂᓐᓂᓐᓂᓐᓂᓐᓂᓐᓂᓐ NUNATSIAQ NEWS

August 3, 2007

Greenhouse gives Iqaluit fresh produce

"This is what romaine lettuce should taste like."

JOHN THOMPSON

Iqaluit may be experiencing a mostly cold and dreary summer, but there's one spot in town where it's sensible to wear shorts and a t-shirt: the newly-opened community greenhouse.



Peter Workman waters tomatoes inside Iqaluit's community greenhouse on Sunday, July 29. (PHOTO BY JOHN THOMPSON)

Total Energy Cycle...

What does it mean? How do we do it?

Jatropha Bio-diesel & Cold Processing

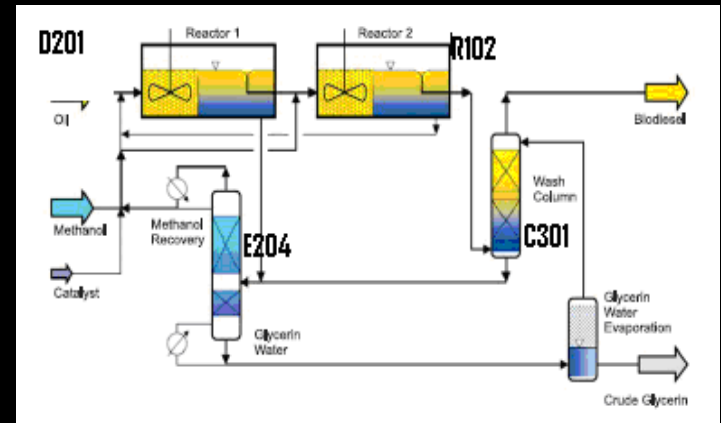

Plantation Metrics/ha

Plants/ha	1,500
Seeds/plant	3.23kg
Seeds/ha	4,850kg
Fertilizer yield	67%
Oil Yield*	33%
Fertilizer (Produced)	3,250kg
Unrefined Jatropha oil	1,600kg

Refinery Metrics

Unrefined Jatropha Oil	1,600kg
Bio-diesel Oil	90%
Glycerin	10%

END PRODUCTS

Bio-diesel production	1,440kg
Glycerin Production	160kg

* Oil yields range from 33%-50%

**All images and Data used with permission of Energy Solutions International. Do not redistribute without permission.

Total Energy Cycle...

What does it mean? How do we do it?

World's-First Biofuel Test Flight

The world's first commercial aviation test flight powered by a sustainable second-generation biofuel took place on Tuesday 30 December, 2008 by Air New Zealand.



Why is this important?

In the far North, Air Mobility is Vital and forms a portion of the pricing of nearly everything.

Total Energy Cycle...

What does it mean? How do we do it?

Hydrogen

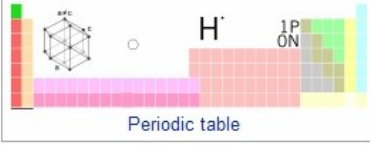
1	(none) ← hydrogen → helium
	Periodic table
General	
Name, symbol, number	hydrogen, H, 1
Element category	nonmetal
Group, period, block	1, 1, s
Appearance	colorless gas
Standard atomic weight	1.00794(7) g·mol ⁻¹
Electron configuration	1s ¹
Electrons per shell	1 (Image)

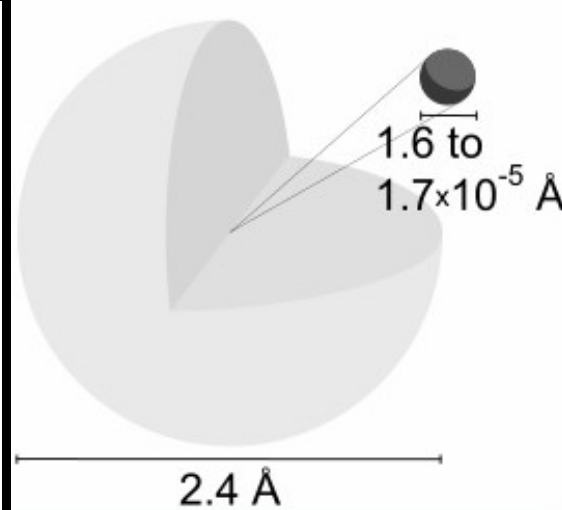

Hydrogen is of itself an energy carrier, but the energy density is low and new fuel handling, and distribution systems would need to be built for use. Further there are few motive sources which can use Hydrogen as a direct fuel source.

Hydrogen is an energy carrier, it is not a source of energy!!!

Total Energy Cycle...

What does it mean? How do we do it?

Synthetic fuels from atmospheric CO₂

(The opposite of Global Warming...*sort of*)

The Majority of the remainder of the presentation will be based on

United States Patent 4,568,522

[54] **SYNFUEL PRODUCTION SHIP**

[75] Inventor: **Marshall J. Corbett, East Northport,
N.Y.**

[73] Assignee: **Grumman Aerospace Corporation,
Bethpage, N.Y.**

[21] Appl. No.: **417,309**

[22] Filed: **Sep. 13, 1982**

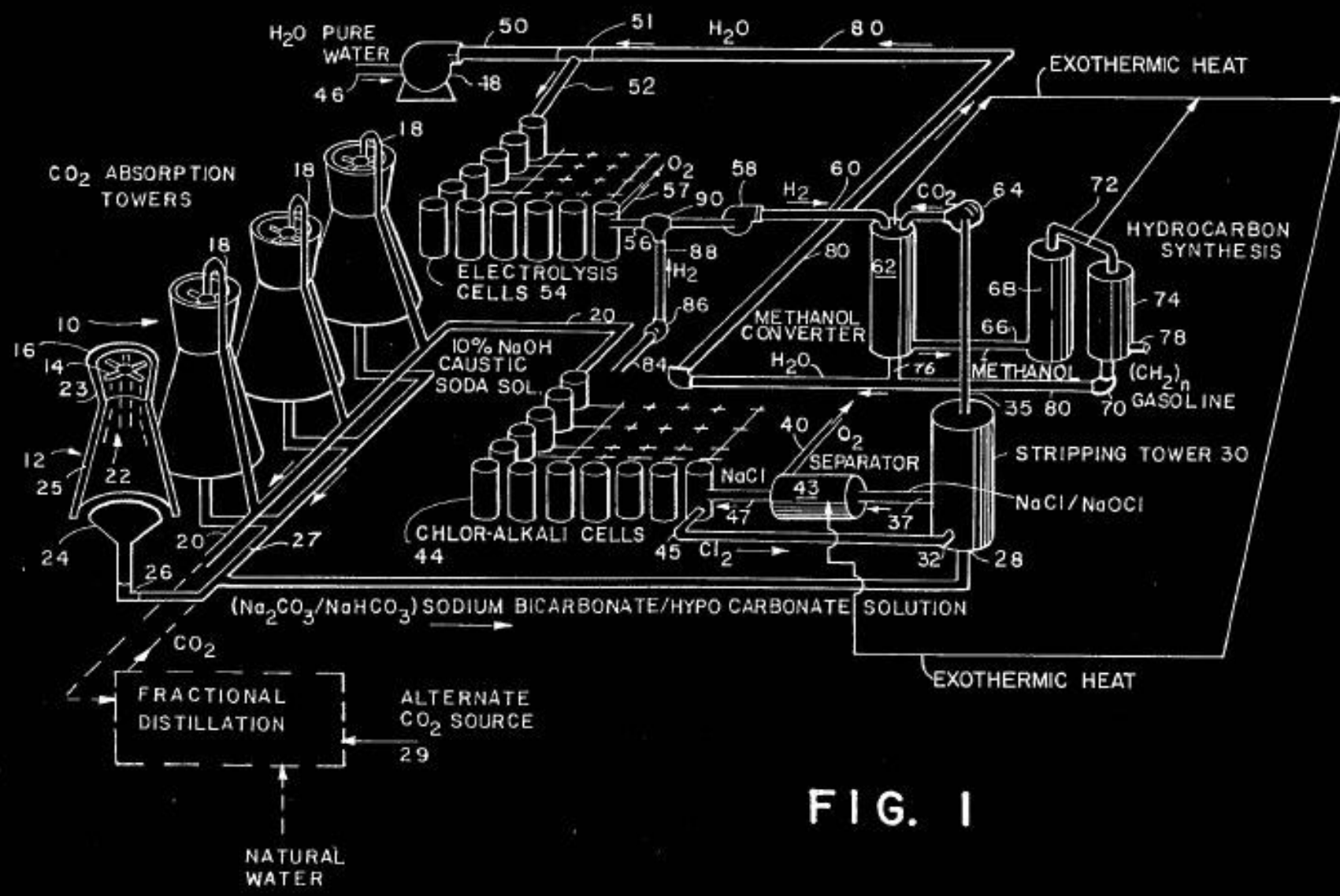

FIG. 1

Total Energy Cycle...

What does it mean? How do we do it?

Synthetic fuels from atmospheric CO₂

SYN. GAS COMPONENT	PROCESS & EQUATION	EQUIPMENT
(a) HYDROGEN	ELECTROLYSIS OF WATER $2\text{H}_2\text{O} \xrightarrow{e} 2\text{H}_2 + \text{O}_2$	ELECTROLYTIC CELLS
(b) CARBON DIOXIDE — SODIUM HYPOCARBONATE & SODIUM BICARBONATE	CO ₂ ABSORPTION $2\text{NaOH} + \text{CO}_2 \rightarrow \text{Na}_2\text{CO}_3 + \text{H}_2\text{O}$ $\text{CO}_2 + \text{Na}_2\text{CO}_3 + \text{H}_2\text{O} \rightarrow 2\text{NaHCO}_3$	SPRAY ABSORPTION TOWERS
(c) — CARBON DIOXIDE	CO ₂ STRIPPING $\text{Na}_2\text{CO}_3 + \text{Cl}_2 \rightarrow \text{NaCl} + \text{NaOCl} + \text{CO}_2$ $2\text{NaHCO}_3 + \text{Cl}_2 \rightarrow \text{NaCl} + \text{NaOCl} + 2\text{CO}_2 + \text{H}_2\text{O}$	STRIPPING TOWER
(d) — SODIUM CHLORIDE	OXYGEN SEPARATOR $2\text{NaOCl} \xrightarrow{\Delta} 2\text{NaCl} + \text{O}_2$	BOILER
(e) — CAUSTIC / CHLORINE	CHLOR-ALKALI ELECTROLYSIS $2\text{H}_2\text{O} + 2\text{NaCl} \xrightarrow{e} 2\text{NaOH} + \text{Cl}_2 + \text{H}_2$	ELECTROLYTIC CELLS
(f) METHANOL	$\text{CO}_2 + 3\text{H}_2 \rightarrow \text{CH}_3\text{OH} + \text{H}_2\text{O}$	METHANOL SYN.
(g) GASOLINE	$n\text{CH}_3\text{OH} \rightarrow (\text{CH}_2)_n + n\text{H}_2\text{O}$	HYDROCARBON SYN.

FIG. 2

Total Energy Cycle...

What does it mean? How do we do it?

Synthetic fuels from atmospheric CO₂

Effectively the system strips CO₂ out of the atmosphere in large towers misting a “weak base” (10% Caustic Soda NaOH), inside of large towers with a fan to suck in atmosphere, and a misting system. (*Cooling tower?!!*) The resultants are Sodium Bicarbonate (NaHCO₃), and Sodium Carbonate (*Baking soda, and Wasing Soda effectively*). The resultants are then pumped to a stripping process where they are reacted with Chlorine (Cl₂), stripping off the CO₂. The remaining NaCl, and NaOCl are then sent to a separator which uses heat to remove the O₂, leaving NaCl (Salt, or Brine). The brine is then sent to an electrolyzer which produces Chlorine (Cl₂), and Caustic Soda NaOH, each are then returned to the stripping, and absorption processes.

The CO₂ is reacted with Hydrogen (3H₂) to produce Methanol (CH₃OH) and water (H₂O).

The Methanol is then reacted in a to produce Synthetic Hydrocarbons. Hydrocarbons ranging from “light” gasolines, intermediate Kerosenes, and possibly heavy heating oils can be synthesized.

The Grumman patent estimated that it would produce 600,000 gallons of Gasoline per day from one 860MWe Reactor.

(This is very similar in size to a Bruce/Darlington style CANDU).

On a simple linear estimate, a 10 MW reactor would produce 6977 Gallons of gasoline per day.

Total Energy Cycle...

What does it mean? How do we do it?

Synthetic fuels; Important final Notes

Mobil Corporation has already had a facility (Kapuni and Maui oilfields) to reprocess Methanol to gasoline (MTG) in New Zealand from 1979 to 1996.

Haldor Topsoe (Danish), has also developed a similar process reforming synthesis gas (H₂, and CO₂) directly into Gasoline without the step of forming, and storing the methanol. They claim a higher rate of efficiency of conversion in their process known as TIGAS.

Source: http://www.topsoe.com/Business_areas/Gasification-based/Processes/Gasoline_TIGAS.aspx

The author's of US patent # 4,568,522 "Synfuel Production Ship", foresaw issues regarding the operation of the atmospheric CO₂ towers in cold environments. Specifically that the soda solution in the towers could freeze. The patent specifically mentions the use of the waste heat from the Methanol process to warm the air at the inlet of the towers in cold environments. Which would be necessary almost anywhere in Canada.

Total Energy Cycle...

What does it mean? How do we do it?

Synthetic fuels; Alternate routes to Synfuels

There are at present a number of differing routes to synfuels developing. **Reverse Water Gas Shift Processing** takes the CO_2 to $(\text{CO} + \text{H}_2\text{O})$. Carbon Monoxide (CO) is a root building block of synthetic fuels, and permits the synthesis of nearly all liquid hydrocarbon fuels.

Further there new approaches to carbon capture developing everyday. Sandia National Laboratories is currently developing the CR5 (Counter Rotating Ring Receiver Reactor Recuperator). Which utilizes Cobalt Ferrite rings. When heated to 1427c , the cobalt ejects an oxygen molecule. When it is cooled to 1094 c , the rings are exposed to CO_2 the Cobalt takes 1 Oxygen molecule from the CO_2 , leaving CO which can be used in Synthetic Hydrocarbon fuels.



Sandia researcher Rich Diver assembles a prototype device intended to chemically reenergize carbon dioxide into carbon monoxide, which ultimately could become the building block to synthesize a liquid combustible fuel. (Photo by Randy Montoya)

<http://www.sandia.gov/news/resources/releases/2007/sunshine.html>

So what does all this mean to residents of the North?

Lower cost electricity, heating, food, fuels, shipping, and Air Transport.

Value added services moved to the community, and possibly some export of those value added goods.

Local Employment, new incomes, improved self sufficiency and, increased standards of living.





Total energy supply for remote Human Habitations (Or “Nuclear North of 60”)

With thanks to: Peter Lang (Small reactor Zealot); S.Locke Bogart (Sage of Synfuels, fusion, history, and keeper of reality); Duane Pendergast (CNS Alberta Chair; Energy Solutions International (Cold process Jatropha data, *thanks John!!!*); and My wife, and kids!

Prepared by: Jay Harris
Port Elgin, Ontario, Canada
Band member of Cowesses First Nation